

LUXALON®

LINEAR CEILINGS



LUXALON®

Hunter Douglas is an international industrial group engaged in the manufacture and marketing of a wide range of interior and exterior Architectural Products under the brand name LUXALON®

The current LUXALON® Metal Ceiling range offers the world-wide most comprehensive choice in functional systems, combined with numerous visual options in form, size, finish and colour.

Our position as a market leader in ceilings is reflected by our innovative approach to:

- New product development
- Low cost manufacturing
- Dedicated customer service
- Creative marketing

With wide practical experience and the ability to develop tailor-made solutions, our team of LUXALON® specialists can transform architectural concepts into economical and easily installed metal ceiling solutions.



Why LUXALON®?

Some reasons to choose LUXALON® ceilings

✓ Top Quality

Metal ceilings with an oven cured, technologically developed surface finishing. Humidity resistant, in-house produced, aluminium strip materials in uncompromising thickness and quality. Renowned producer and supplier, global market leader.

✓ Top Durability

Long lasting aluminium panels fixed on steel or aluminium suspension systems. Non-fading panel finishing and rigid materials withstanding frequent handling.

✓ No Maintenance – Easy to Clean

Surface coating does not fade or wear and does not take up moisture or dirt. Removal of possible dust simply by means of a slightly wet cloth.

✓ Flexible Design Options

Largest available choice in panel forms and sizes as well as colours and finishes. Also various undulating ceilings and curved panels possible.

✓ Good Access to the Plenum

All systems designed to allow for easy mounting and de-mounting of the ceiling surface panels.

✓ Acoustics

Various perforation patterns.

✓ Innovative

Pioneer in Linear Metal Ceilings Systems since the 1960's. Launched many self-developed new ceiling products since. Strong connections with the worldwide architects and builders community. Continuous substantial R&D efforts.

✓ Global Brand Name – Local Service

Worldwide presence and production of products through a network of high-quality, selected partners, having best knowledge of local circumstances and requirements and offering direct and quick service.

✓ Environment Friendly

All materials used are fully re-cyclable for production of new panels.

GUIDE TO CEILINGS

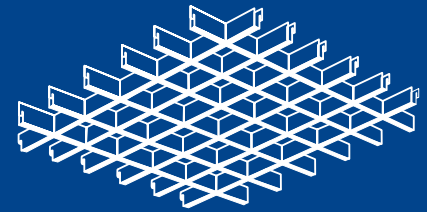

Grid Ceiling

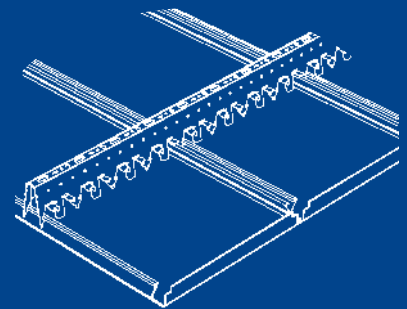

300C Ceiling

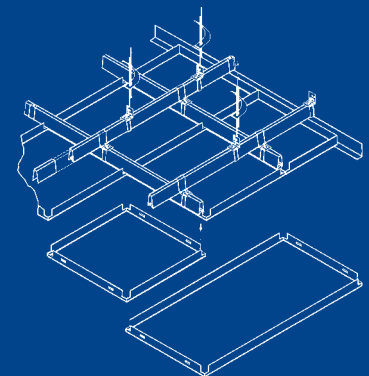

Tile Ceiling

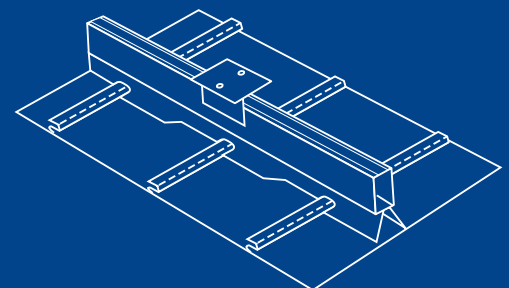

Exterior Ceiling

LUXALON® 84R · 84B · 84C

The simple design and economy of LUXALON® 84 series ceilings provides a wide range of design options. The ability to curve and contour LUXALON® series profile panels has made the ceiling a favourite with architects around the world. These panels are ideally suited for classrooms, libraries, laboratories, lecture theatres, assembly halls, offices and canteens, with the inclusion of acoustic blanket makes it a very effective acoustic ceiling . . . integrated light fittings.

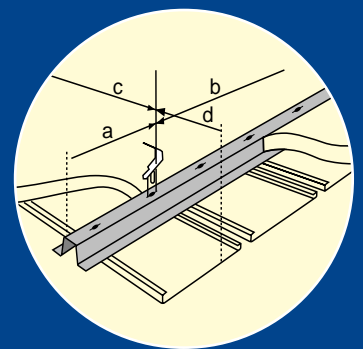
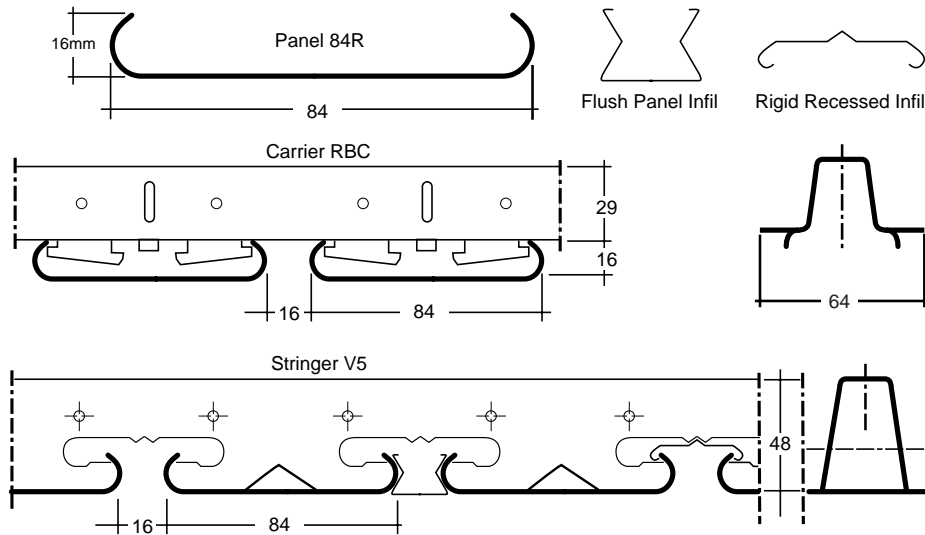

LUXALON® 84R - Short Form Specification

.....m² LUXALON® Aluminium Panel Ceiling. Type 84R consisting of:
 panels made of "Color-cote", 0.5mm thick aluminium, 84mm wide, 16mm deep, with round sides, colour according to LUXALON® Colour Chart.
 Panel carriers made of "Color -Cote", 0.9mm thick aluminium, black satin, 44mm wide and 29mm deep, with prongs to hold panels in a module of 100mm.
 (The 16mm wide gaps between the panels closed with flush join

profiles of "Color-Cote" aluminium.) the edge with (without) edge cover profile with a gap ofmm to the wall.
 Acoustic padsmm thick, densitykg/m², black one side, laid on top of the panels between the panel carriers.
 Fixing system for a suspension height ofmm and its fastening to the structural ceiling including (excluding) scaffolding with a room height ofmm.
 Supply and fix according to the fixing instructions of Hunter Douglas Architectural Products Pty Limited.

CARRIER SPAN IN mm			PANEL SPAN IN mm			
Acoustic Pad			On 2 carriers		On more carriers	
	a	b	c	d	c	d
Without	300	1700	1500	150	1700	150
With	300	1700	1300	150	1500	150

LUXALON® 84B - Short Form Specification

.....m² LUXALON® Aluminium/ Zincalume Panel Ceiling. Type 84B consisting of:
 panels made of "Color-cote", 0.5mm thick aluminium/0.35mm zincalume, 84mm wide, 16mm deep, with round sides, colour according to LUXALON® Colour Chart.
 Panel carriers made of "Color -Cote", 0.9mm thick aluminium, black satin, 44mm wide and 29mm deep, with prongs to hold panels in a module of 100mm.
 (The 16mm wide gaps between the panels closed with flush join

profiles of "Color-Cote" aluminium.) the edge with (without) edge cover profile with a gap ofmm to the wall.
 Acoustic padsmm thick, densitykg/m², black one side, laid on top of the panels between the panel carriers.
 Fixing system for a suspension height ofmm and its fastening to the structural ceiling including (excluding) scaffolding with a room height ofmm.
 Supply and fix according to the fixing instructions of Hunter Douglas Architectural Products Pty Limited.

CARRIER SPAN IN mm			PANEL SPAN IN mm			
Acoustic Pad			On 2 carriers		On more carriers	
	a	b	c	d	c	d
Without	300	1700	1450	150	1660	150
With	300	1700	1250	150	1450	150

LUXALON® 84C - Short Form Specification

.....m² LUXALON® Aluminium Panel Ceiling. Type 84C consisting of:
 panels made of "Color-cote", 0.5mm thick aluminium, 84mm wide, 12.5mm deep, with recessed flange of 23.9mm, colour according to LUXALON® Colour Chart.
 Panel carriers made of "Color -Cote", 1.0mm thick aluminium, black satin, 32mm wide and 39mm deep, with cut-outs to hold panels in a module of 100mm.
 The edges with (without) edge cover profile with a gap

ofmm to the wall, acoustic padsmm thick, densitykg/m², black one side, laid on top of the panels between the panel carriers.
 Fixing system for a suspension height ofmm and its fastening to the structural ceiling including (excluding) scaffolding with a room height ofmm.
 Supply and fix according to the fixing instructions of Hunter Douglas Architectural Products Pty Limited.

CARRIER SPAN IN mm			PANEL SPAN IN mm			
Acoustic Pad			On 2 carriers		On more carriers	
	a	b	c	d	c	d
Without	300	1300	1600	150	1800	150
With	300	1300	1400	150	1600	150

Note: Profile 84R is available in hole perforated and ribbed, Profile 84B/84C is available in both hole perforated and bridged rib.

LUXALON® 50 Series / Multi-Panel

With five panel widths to choose from, LUXALON® Multi-Panel ceilings gives architects unlimited opportunities for creativity. Panels clip to a single carrier, enabling wide, intermediate and narrow panels to be used in the same installation.

Panels are standard and perforated, in 30mm, 80mm, 130mm and 180mm widths.

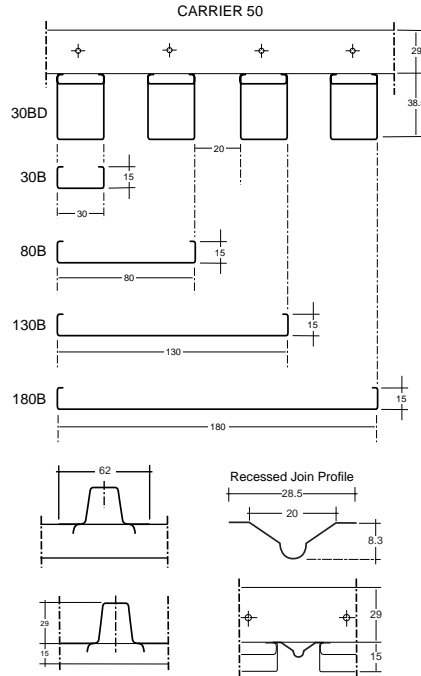

LUXALON® V100 / V200

LUXALON® V100 and V200 Decorative Screen Ceilings are ideal for visually lowering areas and for concealing pipes and other overhead installations. They can also be used to effectively diffuse natural and artificial light.

LUXALON® Screen Ceilings consist of lightweight, free-hanging aluminium panels which can be clipped to carriers at spacings of 100mm, 150mm and 200mm to give a closed appearance, while still allowing easy access to building services.



Integrated Lighting

An exclusive and comprehensive range of lighting is available which integrates with all LUXALON® ceilings. The Intalite® brand range includes fluorescent strip lights, recessed downlights for all lamp sources, low voltage fittings and high performance fluorescent troffers.

Importantly, light fittings can be colour matched to the various ceiling panel types, with more than 32 colours available.



LUXALON® Multi-Panel - Short Form Specification • 30BD/30B/80B/130B/180B

.....m² LUXALON® Aluminium Panel Ceiling, Type 30BD/30B, consisting of:

Panels made of "Color-Cote", 0.5mm thick aluminium alloy, 30/80/130/180mm wide, 38.5mm or 15mm deep, with square sides, colour according to LUXALON® Colour Chart.

Panel carriers made of 1.0mm thick aluminium, black satin, 62mm wide and 29mm deep, with prongs to hold panels in a module of 50mm, the edges with (without) edge cover profile with a gap of

.....mm to the wall, acoustic padsmm thick, densitykg/m³, black one side, laid on top of the panels between the panel carriers.

Fixing system for a suspension height ofmm and its fastening to the structural ceiling including (excluding) scaffolding with a room height ofmm.

Supply and fix according to the fixing instructions of Hunter Douglas Architectural Products Pty Limited

Type	Acoustic Pad	CARRIER SPAN IN mm		PANEL SPAN IN mm			
		a	b	On 2 carriers		On more carriers	
				c	d	c	d
30BD	Without	300	1700	2300	150	2300	150
	With	300	1700	2500	150	2500	150
30B/80B	Without	300	1700	1350	150	1650	150
	With	300	1700	1550	150	1850	150
130B	Without	300	1700	1250	150	1550	150
	With	300	1700	1450	150	1750	150
180B	Without	300	1700	1150	150	1450	150
	With	300	1700	1350	150	1650	150

LUXALON® V100 / V200 - Short Form Specification

.....m² LUXALON® Aluminium Screen Ceiling, Type V100 (V200) consisting of:

Panels made of "Color-Cote", 0.6mm thick aluminium alloy, with profiled sides, 101mm (200)mm high, colour according to LUXALON® Colour Chart.

The V-type panel carriers made of 1.0mm thick "Color-Cote", white satin, (black satin), 300mm wide and 90mm high, with cut-

outs to hold panels in a module of 100mm (150mm, 200mm, special module between 100mm and 200mm).

Fixing system for a suspension height ofmm and its fastening to the structural ceiling including (excluding) scaffolding with a room height ofmm.

Supply and fix according to the fixing instructions of Hunter Douglas Architectural Products Pty Limited

	CARRIER SPAN IN mm				PANEL SPAN IN mm			
	With 2 fixing points			With more fixing points				
	a	b		a	b		c	d
		V100	V200		V100	V200		
100mm	500	1700	1450	500	200	1700	2100	600
100mm	500	1850	1600	500	2200	1900	2100	600
100mm	500	2000	1750	500	2350	2050	2100	600

LUXALON® Hushpoly

LUXALON® Hushpoly sound absorbing blanket is an exclusive component of the LUXALON® linear ceiling/lighting system. Made from polyester fibres and finished with a matt black face for total blackout, the bulk density-to-air ratio of Hushpoly ensures optimum acoustic performance.

It has a low fire rating and is user-friendly, with no special protection required by installers. Three types of hushpoly are available, including two for high performance installations.

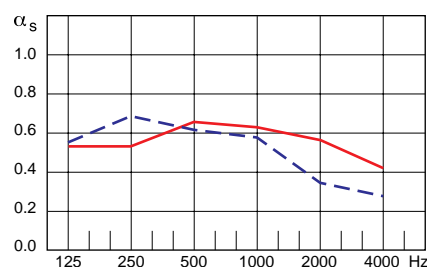

Red curve - unperforated panels, gap 16mm (module 100mm), 30mm LUXALON Hushpoly AB30 (polyester fibres) 400mm plenum depth.

Blue curve - unperforated panels, gap 16mm (module 100mm), 50mm fibreglass blanket 9kg/m³, 400mm plenum depth.

CEILING S

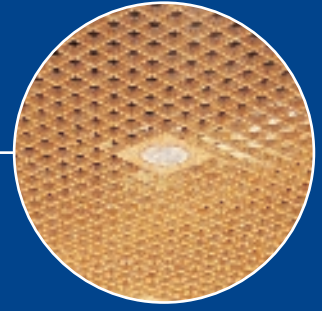

FACADE S



CLADDING



SUN CONTROL



HUNTER DOUGLAS ARCHITECTURAL PRODUCTS

A Division of Hunter Douglas Limited. ABN 98 009 675 709

HEAD OFFICE

338 Victoria Road, Rydalmere NSW 2116

Phone: (02) 9638 8824 Fax: (02) 9638 8826

E-mail: enquiries@luxalon.com.au

LUXALON®

Contact us for more information
and product samples.

Visit our website: www.luxalon.com.au